

TOSUN



Tlog1039 Product Manual

Version: V3.0 | English

tosunai.com

Copyright Information

Shanghai TOSUN Technology Ltd

No. 9 Building, 1288 Jiasong North Road, Jiading District, Shanghai (Headquarters)

Buildings 14-17, Lane 4849 Cao'an Highway (Shanghai Research Institute)

In an effort to provide users with the best possible service, Shanghai TOSUN Technology Ltd. (hereinafter referred to as “TOSUN Technology”) has made every attempt to present accurate and detailed product information as possible in this manual. However, due to the time-sensitive nature of the content, TOSUN Technology cannot guarantee the timeliness and applicability of the information at all times.

The information and data contained in this manual are subject to change without prior notice. For the latest updates, please visit the [official website of TOSUN Technology](#) or contact our support team directly. We appreciate your understanding and continued support!

No part of this manual may be reproduced in any form or by any means without prior written permission from TOSUN Technology.

@ Copyright 2026-2027, Shanghai TOSUN Technology Ltd. All rights reserved.

What Are the Advantages of Tlog1039?

- **Multi-Bus Technology**

Tlog1039 supports CAN/CAN FD, LIN, and Automotive Ethernet simultaneously. In complex bus network environments, a single Tlog1039 device enables communication with multiple ECUs across different bus protocols.

- **Multi-Channel Support**

Tlog1039 is equipped with a rich set of bus interfaces, supporting up to 12 channels of CAN/CAN FD, 10 channels of LIN. Additionally, it offers 3 Ethernet ports, easily meeting multi-channel requirements across a wide range of application scenarios.

- **High Performance**

Built with high-performance hardware, Tlog1039 ensures reliable data processing even under demanding network loads. It connects to the PC via Ethernet, ensuring high-speed and stable data exchange with the host system.

- **Cost Efficiency**

By integrating multiple bus technologies, Tlog1039 reduces the need for separate communication modules, effectively lowering hardware costs and simplifying wiring complexity.

- **Seamless Software Integration**

Tlog1039 is fully integrated with the TSMaster software, enabling streamlined monitoring, analysis, and simulation of multi-bus communication. It supports advanced automotive protocols including UDS diagnostics, ECU flashing, CCP/XCP calibration, making it ideal for development, testing, and validation environments.



What Can It Do?

- Monitor, capture, and decode CAN/CAN FD bus data
- Monitor, capture, and decode LIN bus data
- Support DIDO (Digital Input/Output) and AIAO (Analog Input/Output)
- Bus log data storage and export
- Perform ECU flashing (via UDS or DoIP)
- Execute ECU-level and system-level automated testing
- ...

How to Use the Tlog1039 Device?

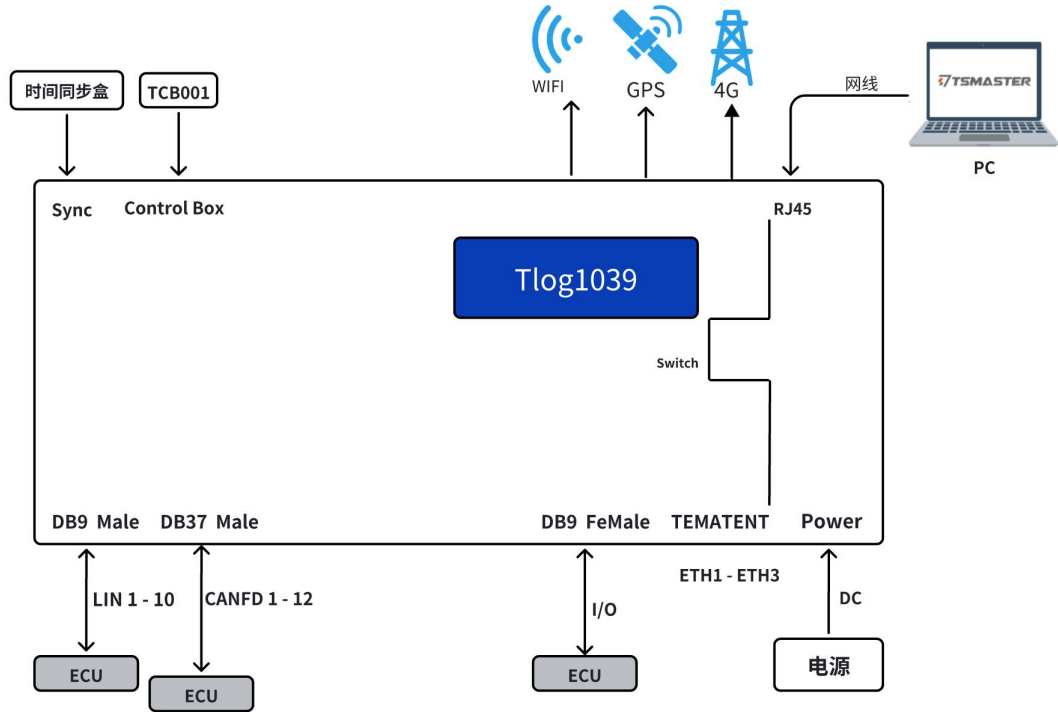

Contents

1. About this User Manual	7
1.1 Disclaimer	7
1.2 Copyright	7
2. General Information	8
2.1 Bus Data Collection and Analysis	8
2.2 Bus Simulation	9
2.3 Diagnostic	10
2.4 Calibration	11
3. Tlog1039	13
3.1 Overview	13
3.2 Features	14
3.3 Technical Data	15
3.4 Electrical Data	16
3.5 Mechanical Dimensions	17
3.6 Packing List	18
3.7 Hardware Interface	21
LED Indicators	24
3.9 Optional Accessories	26
4. Quick Start	27
4.1 System Connections	27
4.2 Driver Installation	27
4.3 Software Overview	28
4.4 Software Installation	29
4.5 Hardware Integration with TSMaster	29
5. Inspection and Maintenance	32
6. Appendix	34

1. About this User Manual

1.1 Disclaimer

The information provided in this document is for reference only and does not constitute any form of guarantee or commitment by TOSUN. TOSUN Technology reserves the right to modify the contents and data in this document without prior notice. The company assumes no responsibility for the accuracy of the information contained herein or for any damages resulting from the use of this document. We sincerely appreciate any error reports or suggestions for improvement, as they help us deliver more efficient products in the future.

1.2 Copyright

All rights to this document and its contents are reserved by TOSUN Technology. No part of this document may be reproduced, distributed, transmitted, disseminated, republished, or otherwise used in any form or by any means without the explicit prior written permission of TOSUN Technology.

2. General Information

2.1 Bus Data Collection and Analysis

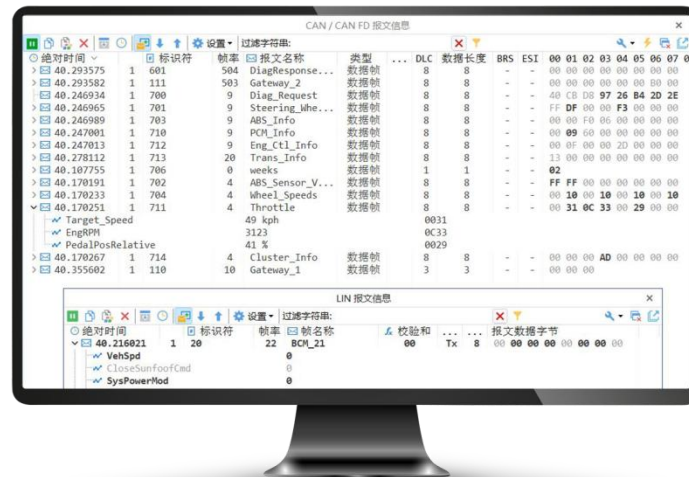

When used with TSMaster software, Tlog1039 supports message transmission/monitoring/playback, bus statistics/logging, and graphical/numerical data analysis.

- **Bus Statistics**

Bus statistics include: bus load rate, peak load rate, data frame rate, data frame count, error frame rate, error frame count, controller status, and transmit error count.

- **Database**

Supports loading DBC, LDF, XML, ARXML format databases. Provides database structure view, signal communication matrix, and message communication matrix views.

- **Message Playback**

Supports offline and online playback of recorded files in formats such as BLF and ASC.

- **Message Transmission**

Supports manual transmission, hotkey triggering, and cyclic transmission. Message generator and both custom and database-based messages are supported.

- **Message Monitoring**

Offers multiple display modes, and supports DBC decoding to view signal values. Channel and ID filtering can be configured.

- **Graphical & Numerical Display**

Y-axis of signals is fully configurable. Supports multi-axis and split-display modes, as well as pinpoint data visualization, making analysis more intuitive and accurate.

2.2 Bus Simulation

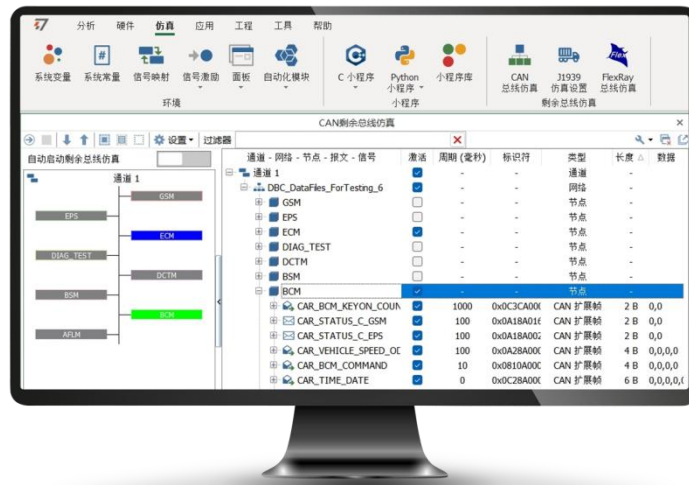

Together with TSMaster software, Tlog1039 enables multi-bus simulation including CAN, LIN, as well as code simulation via Desktop HIL (hardware-in-the-loop) features. The built-in Panel function allows graphical visualization of signal data linked to bus channels.

- Supports CAN bus simulation
- Supports LIN bus simulation
- Supports J1939 protocol simulation

2.3 Diagnostic

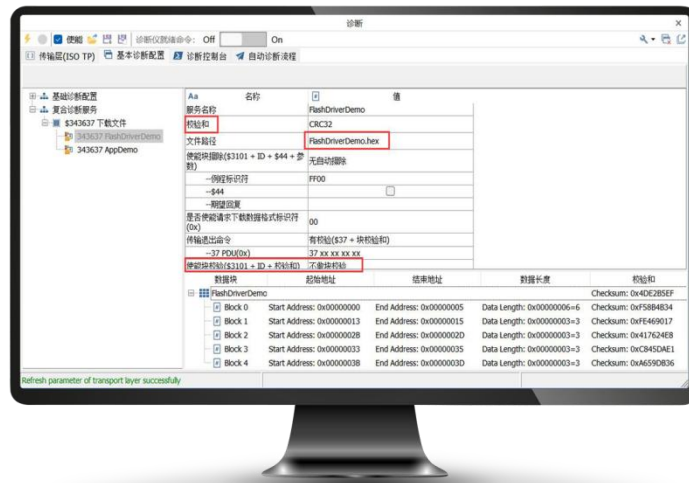

Diagnostics are a key functionality of modern ECUs. During vehicle operation, sensors throughout the system detect various potential faults in electrical and electronic subsystems. TOSUN toolchain supports the development, verification, and UDS-based ECU flashing needed for these diagnostic operations.

- **Diagnostic Parameter Configuration**

Includes timeout settings, TesterPresent configuration, SeedKey DLL configuration. Built-in SeedKey editor allows custom algorithms without third-party tools.

- **Basic Diagnostic Configuration**

Users can define custom diagnostic database, including: service setup, request/response parameters, and more.

- **Diagnostic Console**

Executes configured diagnostic database, with support for automatic verification of response results.

- **Automated Diagnostic Process**

Supports creating customized diagnostic flows and services, enabling streamlined Flash Bootloader programming processes.

2.4 Calibration

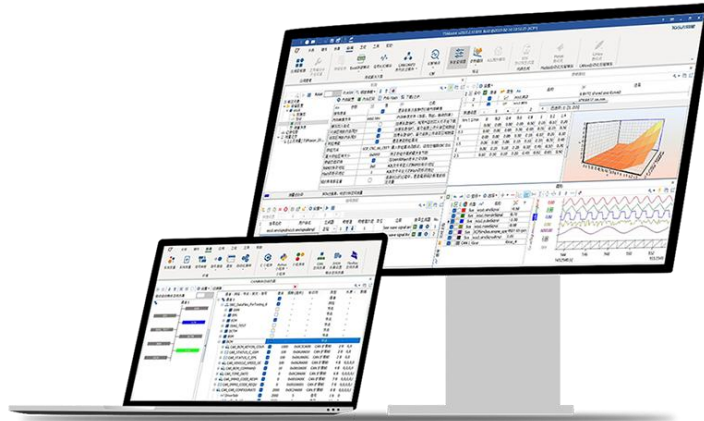

CCP (CAN Calibration Protocol): A CAN-based protocol mainly used for ECU calibration and parameter tuning. It allows engineers to read/write parameters and perform real-time testing and adjustment.

XCP (Universal Measurement and Calibration Protocol): A versatile protocol supporting multiple communication interfaces such as CAN and Ethernet. It offers high-speed data transfer and advanced diagnostic capabilities.

The automotive calibration function is a technique used in ECU development and diagnostics. It involves adjusting ECU parameters and calibration values to optimize vehicle performance and functionality. CCP and XCP allow for efficient communication between engineers and the ECU for tuning and optimizing vehicle performance.

- Supports importing A2L files
- Supports DAQ/Polling measurement modes

- Memory configuration with image loading and checksum methods
- Supports parameter curves and MAP visualizations
- Supports MDF/MF4 file storage and playback
- Graphical display for variables
- Supports management in .par or .hex format
- Integrated view for message analysis, diagnostics, calibration, and system variables
- Supports automation through system variable scripting
- Supports both single and multiple file downloads

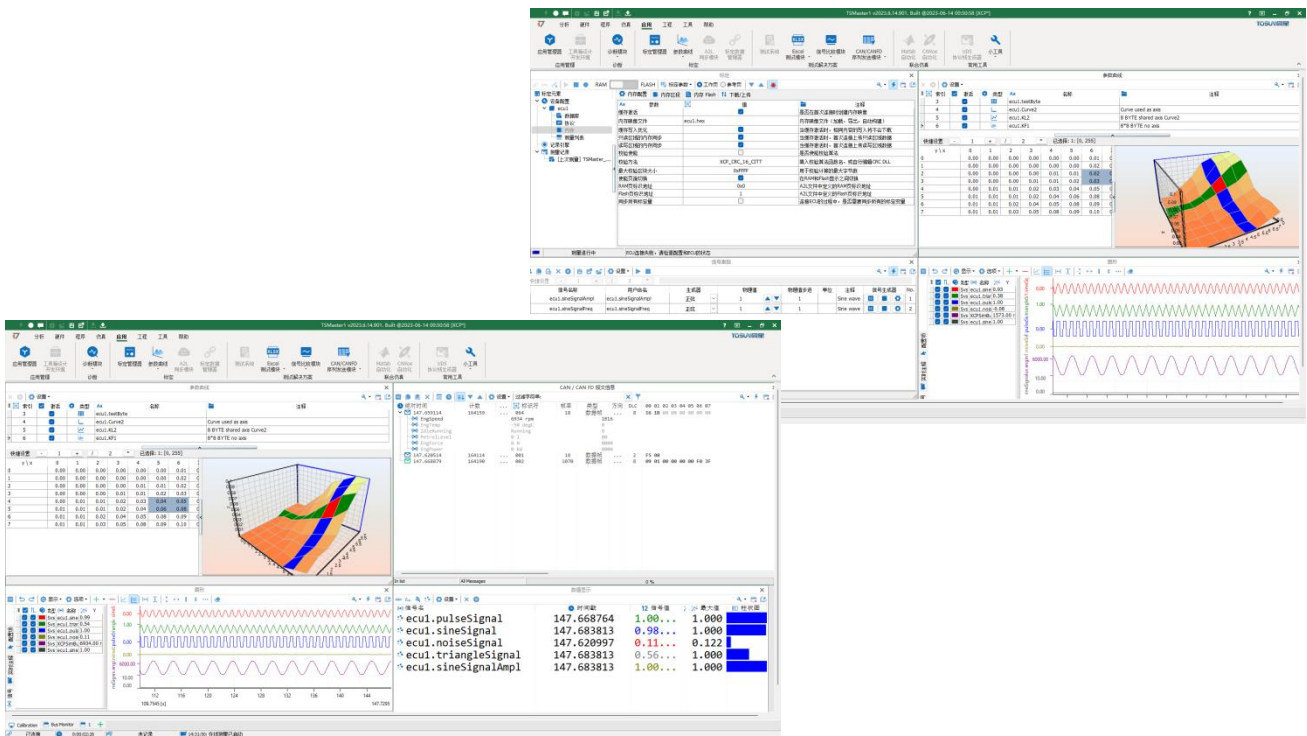

3. Tlog1039

3.1 Overview

The Tlog1039 is a multi-bus simulation, testing, and data logging instrument that supports CAN/CAN FD, LIN, and Ethernet communication buses.

- 12-channel CAN/CAN FD:
 - Adjustable baud rate from 125 kbps to 1 Mbps under the CAN protocol.
 - Under the CAN FD protocol, the standard configuration supports up to 5 Mbps.
- 10-channel LIN:
 - LIN slave nodes are fully software-configurable.
 - LIN1 - LIN4 can also be configured as master nodes.
 - Supports baud rates from 0 to 20 kbps.
- 3-channel 100/1000Base-T1 Ethernet:

Additionally, the Tlog1039 integrates multiple digital and analog I/O interfaces, enabling flexible signal measurement and system integration across various testing scenarios.

The device connects to a PC via Ethernet, ensuring high-speed data transmission and preventing communication bottlenecks during large-scale bus data processing. It also supports wireless access through 4G, Bluetooth, and Wi-Fi connections.

When used with the powerful TSMaster software, the Tlog1039 supports database files in DBC, LDF, XML, and ARXML formats, allowing users to conveniently monitor, analyze, and simulate bus communication data. It also supports UDS diagnostics, ECU flashing, and CCP/XCP calibration, providing a comprehensive solution for automotive network testing and development.



3.2 Features

- ✓ Hardware-based message timestamping with microsecond-level accuracy, meeting advanced timing requirements
- ✓ Driver-free design for Windows
- ✓ 12 CAN channels (supporting CAN/CAN FD), and 10 LIN channels, and 3 Ethernet channels
- ✓ Supports 4 Digital I/Os and 3 Analog I/Os
- ✓ Configurable CAN baud rate from 125 kbps to 1 Mbps under CAN protocol; configurable CAN FD baud rate from 125 kbps to 1 Mbps
- ✓ All LIN slave nodes configuration via software; LIN1 - LIN4 also support master node configuration via software
- ✓ CAN channels support Self-ACK (self-acknowledgement) mode
- ✓ 2500V isolation on CAN channels
- ✓ Supports BLF format data logging, export and online playback through the PC host software
- ✓ Multi-device hardware time synchronization support
- ✓ Equipped with 128GB eMMC onboard storage as standard, expandable up to 8 × 128GB (optional)
- ✓ Compatible with the TCB001 Keypad Box for event marking during data recording

- ✓ Example project and API interfaces provided, simplifying secondary development

3.3 Technical Data

Channel	12 × CAN FD 10 × LIN 4 × DI/DO 3 × AI/AO 3 × ETH (3 × 100/1000Base-T1 Automotive Ethernet)
PC Interface	RJ45 Ethernet
CAN Interface	DB37 Male
LIN Interface	DB9 Male
I/O Interface	DB9 Female
Driver	Driver-free for Windows
Buffering	Hardware-level buffering to ensure no frame loss
CAN	Supports CAN 2.0A/B per ISO 11898-1, with baud rate 125 kbps -1 Mbps
CAN FD	Supports both ISO and non-ISO CAN FD, with baud rates from 125 kbps to 5 Mbps
LIN	Supports LIN 1.3 and LIN 2.x, with baud rates from 0 to 20 kbps
Timestamp	1 μs hardware-level timestamp accuracy
Termination (CAN)	No internally terminated
Isolation	DC 2500 V isolation per CAN channel
DI/DO	DI: 0-40 V Vref:0-3.3 V, Thresholds: $V_{AH}=(330+499*V_{ref})/1098$; $V_{Al}=0.455*V_{ref}$ DO: Low 0V, high 12 V (no load support)
AI/AO	AI: 0-39 V AO: 0-30 V
Power Supply	DC
Power Consumption	10 W

Enclosure Material	Metal enclosures
Dimensions	210*110*47 mm
Weight	2884.4 g
Operating Temp.	-40 °C~ 80 °C
Operating Humidity	10% ~ 90% RH (non-condensing)
Environment	Avoid corrosive gases

3.4 Electrical Data

Parameter		Test Conditions	Min	Typical	Max	Unit
Operating Voltage	DC input	All channels active (12x CAN, 10x LIN, 3x ETH PING, 4x DI/DO, 3x AI/AO)	9	12	36	V
Operating Current	DC input	All channels active (12x CAN, 10x LIN, 3x ETH PING, 4x DI/DO, 3x AI/AO)	--	0.6	--	A
Power Consumption	DC input	All channels active (12x CAN, 10x LIN, 3x ETH PING, 4x DI/DO, 3x AI/AO)	--	7.2	--	W
CAN Interface	Bus pin voltage tolerance	CANH、CANL	-58	--	58	V
	Terminal resistor	Not integrated	--	--	--	Ω
	Isolation voltage	Leakage current < 1mA	2500	--	--	VDC

LIN Interface	Bus pin voltage tolerance	LIN1 to GND	-30	--	30	V
EMC (Electromagnetic Compatibility)	EFT (Electrical Fast Transient)	Complies with IEC 61000-4-4 standard	2	--	--	kV

3.5 Mechanical Dimensions

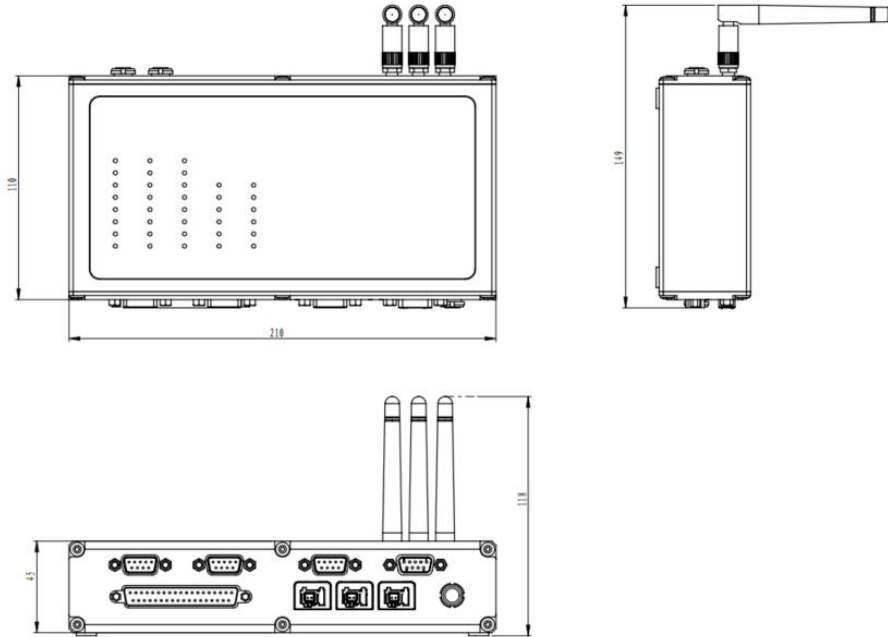

3.6 Packing List

- ✓ Main device: Tlog1039



- ✓ Time synchronization cable *1



- ✓ Tlog1039 power supply cable *1



- ✓ Category 6 Gigabit Ethernet cable *1



- ✓ DB37 female to 12-way DB9 signal cable *1



- ✓ DB9 to 8 banana LIN cable *2

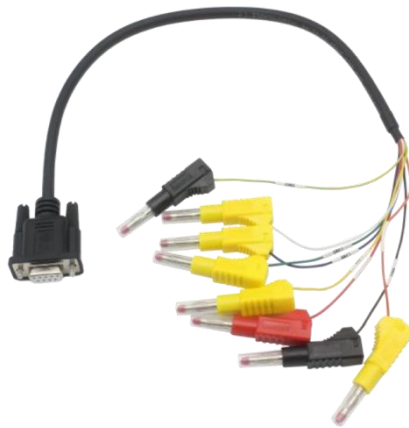

- ✓ DB9 male analog/digital I/O cable *1



- ✓ Antenna *3



- ✓ TCB001 button box cable *1

- ✓ TCB001 button box *1
- ✓ Optional paid accessories (choose one):
 - ✓ H-MTD male to MATenet female Ethernet cable *3



- ✓ MATenet female to H-MTD female Ethernet cable *3

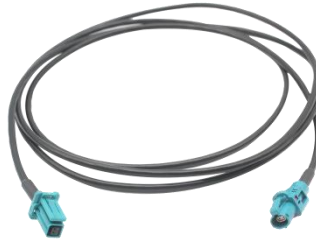

- ✓ MATenet female to MATenet female Ethernet cable *3

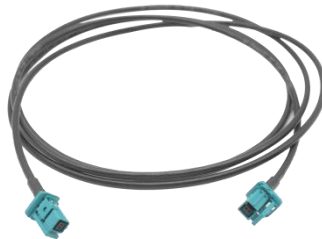

- ✓ Optional paid accessory: TSKT01 mounting bracket *1

3.7 Hardware Interface

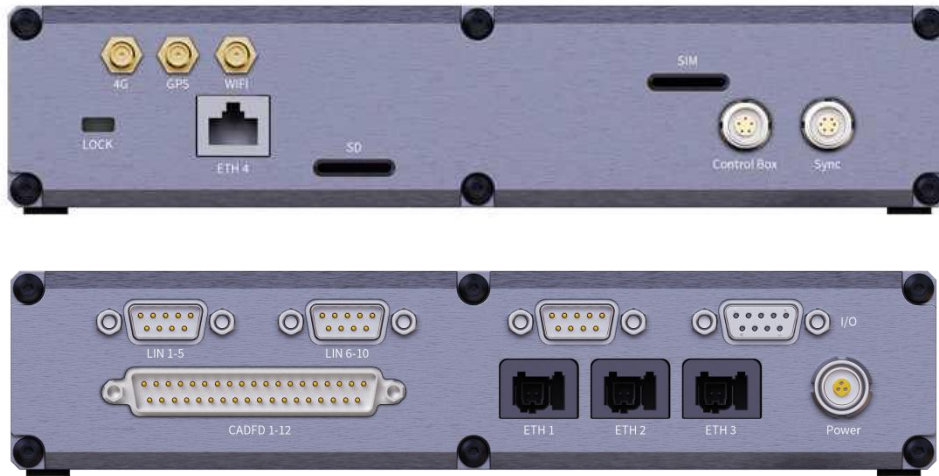

- 1000Base-T (RJ45) interface
- TCB001 interface
- Time synchronization interface
- TE MATEnet Ethernet interface (T1)
- Power interface (3-pin)
- DB37 male (CAN/CAN FD)

PIN Number	Definition	PIN Number	Definition
PIN20	CAN FD1_HIGH	PIN1	CAN FD1_LOW
PIN21	CAN FD_SHIELD	PIN2	CAN FD_GND
PIN22	CAN FD2_HIGH	PIN3	CAN FD2_LOW
PIN23	CAN FD3_HIGH	PIN4	CAN FD3_LOW
PIN24	CAN FD_SHIELD	PIN5	CAN FD_GND
PIN25	CAN FD4_HIGH	PIN6	CAN FD4_LOW
PIN26	CAN FD5_HIGH	PIN7	CAN FD5_LOW
PIN27	CAN FD_SHIELD	PIN8	CAN FD_GND

PIN28	CAN FD6_HIGH	PIN9	CAN FD6_LOW
PIN29	CAN FD7_HIGH	PIN10	CAN FD7_LOW
PIN30	CAN FD_SHIELD	PIN11	CAN FD_GND
PIN31	CAN FD8_HIGH	PIN12	CAN FD8_LOW
PIN32	CAN FD9_HIGH	PIN13	CAN FD9_LOW
PIN33	CAN FD_SHIELD	PIN14	CAN FD_GND
PIN34	CAN FD10_HIGH	PIN15	CAN FD10_LOW
PIN35	CAN FD11_HIGH	PIN16	CAN FD11_LOW
PIN36	CAN FD_SHIELD	PIN17	CAN FD_GND
PIN37	CAN FD12_HIGH	PIN18	CAN FD12_LOW
		PIN19	CAN FD_GND

➤ DB9 male (LIN)

DB9 Pin	Channel	PIN Number	Definition	Channel	PIN Number	Definition
	LIN 1-5	PIN1	LIN1	LIN 6-10	PIN1	LIN6
		PIN2	-		PIN2	-
		PIN3	LIN2		PIN3	LIN7
		PIN4	GND		PIN4	GND
		PIN5	LIN3		PIN5	LIN8
		PIN6	LIN4		PIN6	LIN9
		PIN7	LIN5		PIN7	LIN10
		PIN8	GND		PIN8	GND

➤ DB9 female (I/O)

DB9 Pin	Channel	PIN Number	Definition
---------	---------	------------	------------

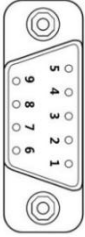
	I/O	PIN1	DIDO1
		PIN2	DIDO3
		PIN3	DGND
		PIN4	AIAO1
		PIN5	AIAO3
		PIN6	DIDO2
		PIN7	DIDO4
		PIN8	AGND
		PIN9	AIAO2

LED Indicators

Diagram of LED indicator:

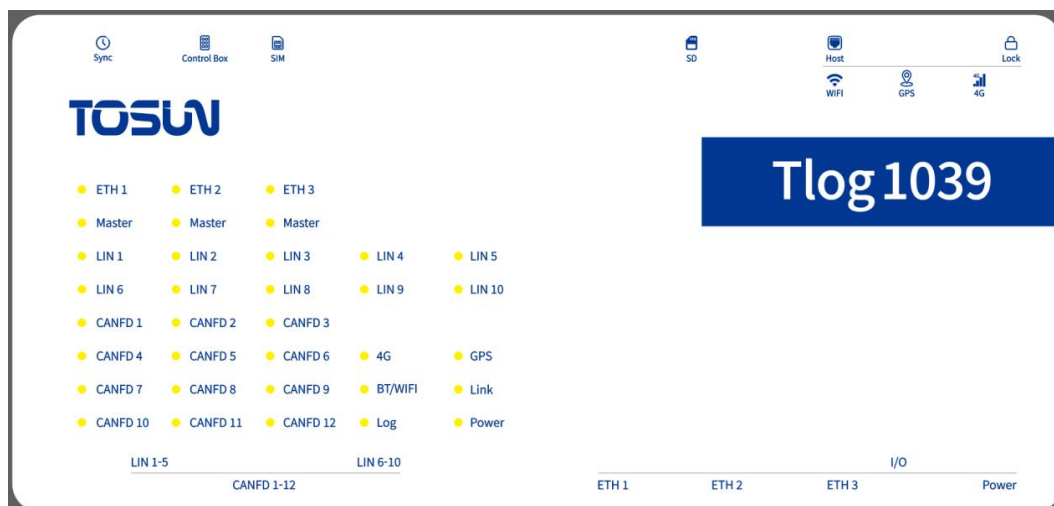

Description of indicator:

Indicator	Definition
ETH 1-3	Indicator for Ethernet channel
Master	Indicator for master/slave mode
LIN 1-10	Indicator for LIN channel
CAN FD 1-12	Indicator for CAN FD channel
Log	Indicator for bus logging
Link	Indicator for connection
Power	Indicator for power

Description of LED color/status:

Color/Status	Description
ETH: Yellow (blinking)	ETH operates in 100Mbps mode
ETH: Green (blinking)	ETH operates in 1Gbps mode
Master: Green (steady)	ETH is the master node

LIN: Green (blinking)	LIN channel transmitting or receiving data correctly
LIN: Red (blinking)	LIN channel sends or receives error frames, indicating a configuration, protocol, or wiring error
CAN FD: Green (blinking)	CAN FD channel transmitting or receiving data correctly
CAN FD: Red (blinking)	CAN FD channel sends or receives error frames, indicating a configuration, protocol, or wiring error
Log: Green (steady)	Device entered logger mode
Log: Green (blinking)	Device is logging data
Log : Green (steady)	Storage space full
Link: Green (steady)	ETH device access normal
Power	Power supply normal

3.9 Optional Accessories

1. Mounting bracket



2. TE MATenet cable

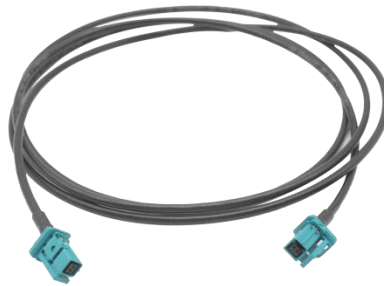

4. Quick Start

4.1 System Connections

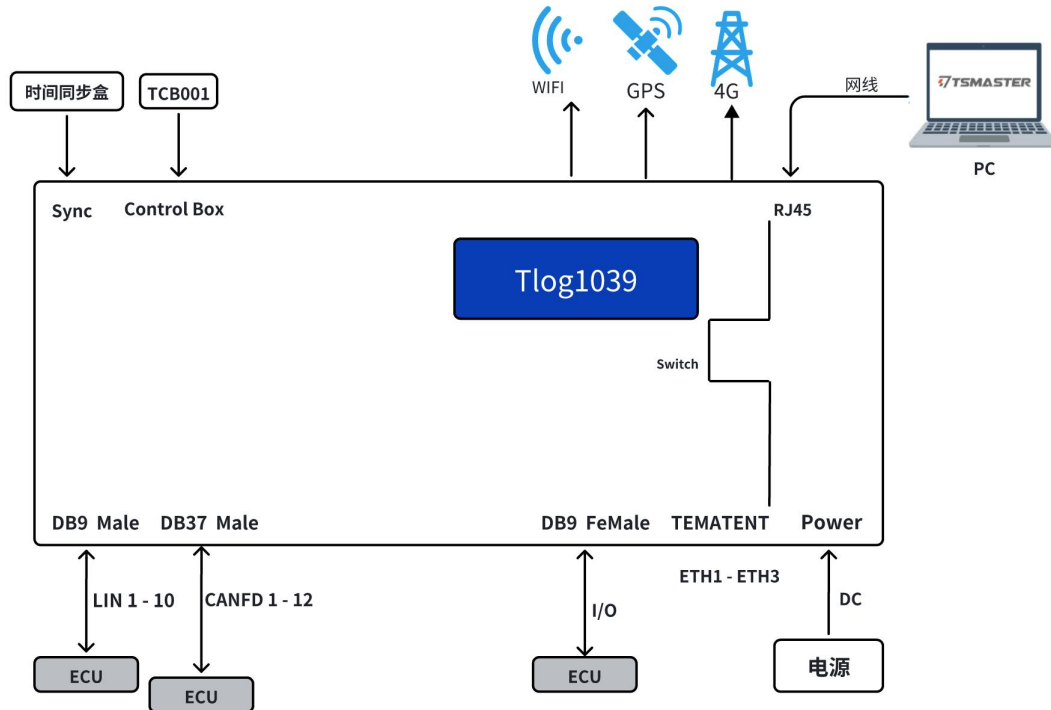

The Tlog1039 is powered through the DC 12V power interface.

Connect the device's RJ45 Ethernet port to your PC. Depending on your testing needs, connect the corresponding CAN/CAN FD, LIN, I/O interfaces to the target ECU.

Once connected, you can control and communicate with the ECU through the TSMaster software on your PC.

4.2 Driver Installation

Driver-free design for Windows, ensuring excellent system compatibility.

4.3 Software Overview

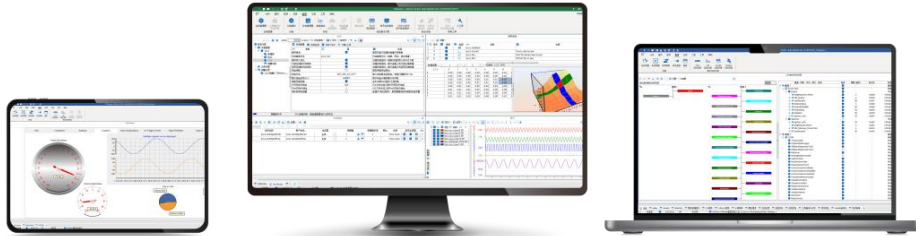

TSMaster is a powerful and versatile tool designed to interface with, configure, and control all TOSUN hardware devices. It supports automotive bus-related functions such as embedded code generation, monitoring, simulation, development, UDS diagnostics, CCP/XCP calibration, ECU flashing, I/O control, measurement, and testing.

TSMaster also supports co-simulation with MATLAB Simulink and CarSim dynamic models for soft real-time HIL testing of ECU algorithms. It provides integrated scripting environments for C and Python, allowing users to execute ECU logic directly within the platform. Additionally, TSMaster offers customizable applets for simulation panels, test sequences, logic design, and automated report generation—making it easy to build complete, automated test systems. Code written within TSMaster is hardware-independent, allowing for easy reuse and deployment across different platforms.

TSMaster is compatible with a wide range of third-party tools and hardware interfaces including Vector, Kvaser, PEAK, IXXAT, and mainstream instruments (e.g., oscilloscopes, waveform generators, DMMs) and I/O cards (AI, DI, DO, etc.). It is designed for seamless integration into test environments, enabling multi-device and multi-channel simulation and testing.

This makes TSMaster ideal for PV/DV testing of automotive ECUs and assemblies, as well as for end-of-line testing in production.

4.4 Software Installation

TSMaster software download link:

<https://www.tosunai.com/downloads/>

If the site is inaccessible, please contact your sales representative or visit the TOSUN official website. Alternatively, you can scan the QR to get the download link.



Once installation, the software icon will be appear on your PC desktop as shown below:



4.5 Hardware Integration with TSMaster

Set the PC's Ethernet IP address to 192.168.1.x to ensure it is in the same subnet as the Tlog1039).

In TSMaster software interface, go to Hardware->Channel Selection. In the left panel of the channel selection window, click Settings and enable Ethernet-type interface device to make the Tlog1039 visible.

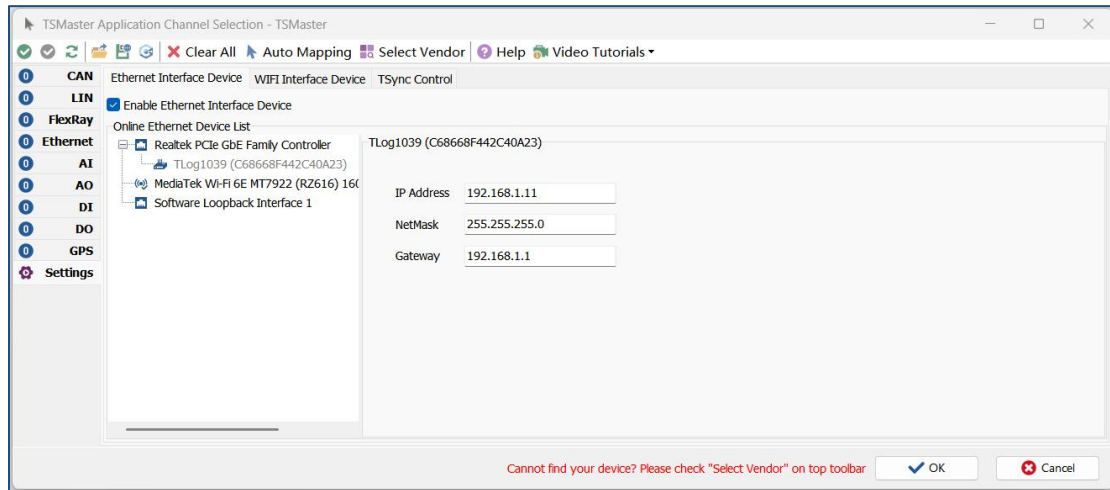

In the “Channel Selection” interface, select the type of bus technology in the left sidebar and configure the number of channels.

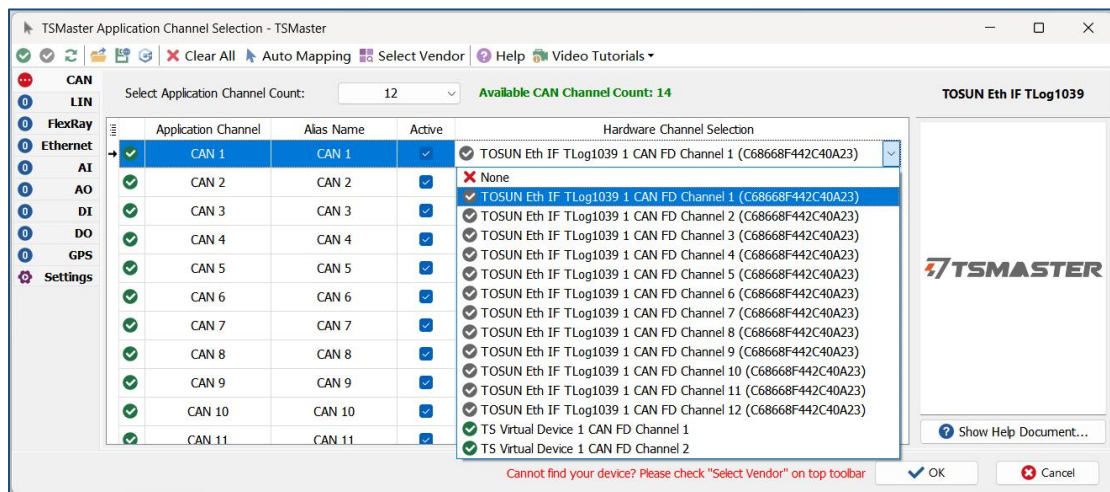

In Hardware Configuration, you can configure controller parameters, such as protocol type, baud rate, controller mode, and terminal resistor activation. (Note: The Tlog1039 does not have built-in terminal resistors, so the terminal resistor activation option can be ignored.)

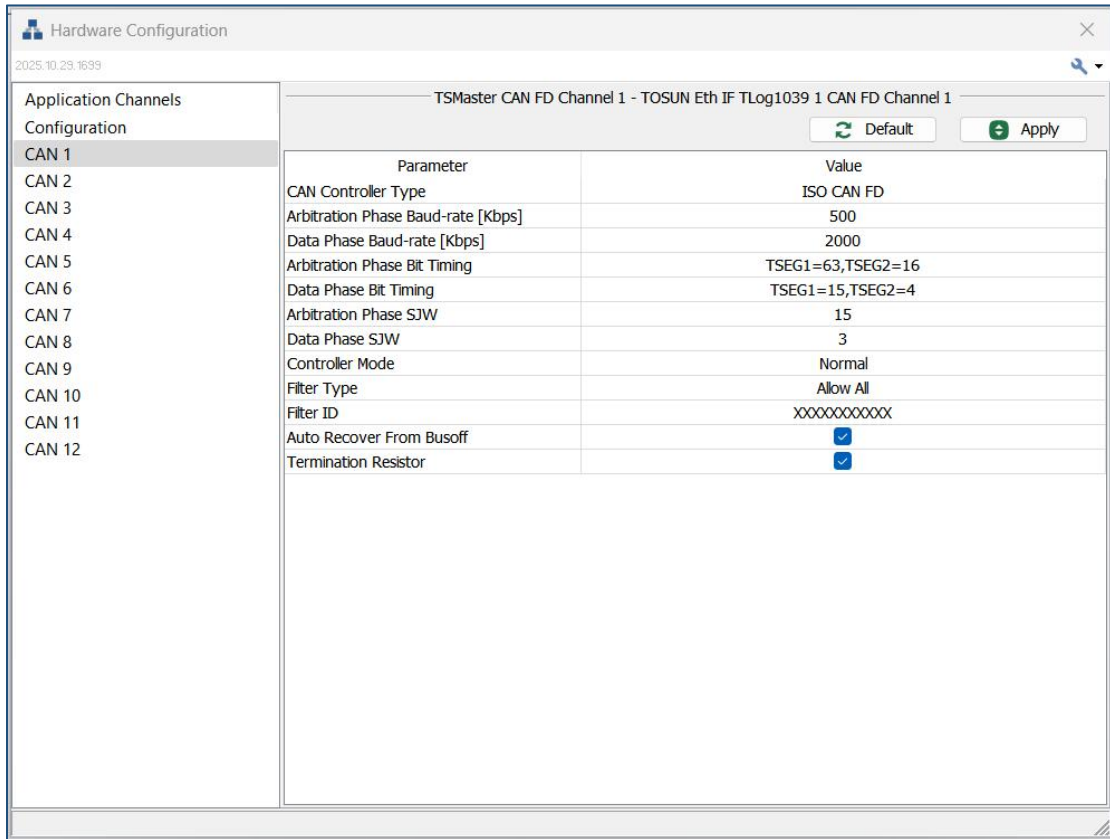

Once configuration is complete, click Analysis->Start to connect the hardware. The Tlog1039, when paired with the TSMaster software, enables efficient development, testing, and production line operations across various automotive bus systems.

For more detailed information on TSMaster usage, refer to the TSMaster software manual and Quick Start Guide.

5. Inspection and Maintenance

The Tlog1039 primarily contains semiconductor components, which typically have a long service life. However, adverse environmental conditions may accelerate aging and degrade performance. To ensure proper operation, regular inspections are recommended to maintain the required environmental conditions.

It is recommended to inspect the device at least once every 6 to 12 months. In harsher environments, inspections should be performed more frequently. Refer to the table below for inspection criteria and recommended actions. If issues persist, please contact Shanghai TOSUN Technology Ltd.

Item	Inspection	Standard	Action
Power Supply	Check voltage fluctuation at power input	+12V DC at power port	Use a voltmeter to verify input voltage. Take corrective actions if out of range.
Ambient Conditions	Check ambient temperature (including internal temperature within enclosures)	-40°C~+80°C	Use a thermometer to ensure temperature is within specified range.
	Check the ambient humidity. (Including internal humidity within enclosures)	10% - 90% RH, non-condensing	Use a hygrometer to ensure humidity is within specified range.
	Check for accumulation of dust, powder, salt, and metal debris	No accumulation	Clean the device and prevent future contamination.
	Check for exposure to water, oil, or chemicals	No exposure	Clean the device and improve environment protection.
	Check for corrosive or flammable gases	No presence	Use sensors or smell detection to verify.

	Check for vibration and mechanical shock	Within allowable limits	Install padding or vibration isolation measures if necessary.
	Check for noise sources near the device	No significant noise sources nearby	Isolate or shield the device from noise sources.
Installation & Wiring	Check crimped connectors in external wiring	Adequate clearance between connectors	Visually inspect and adjust as needed.
	Check for damage to external wiring	No visible damage	Visually inspect and replace damaged cables if necessary.

6. Appendix

Battery Removal Instructions:

- Using tweezers or a small blade, pry open the screw cover on the side where the antenna is located.



- Using a T10 Torx screwdriver, remove the two screws from the end cap at this position.

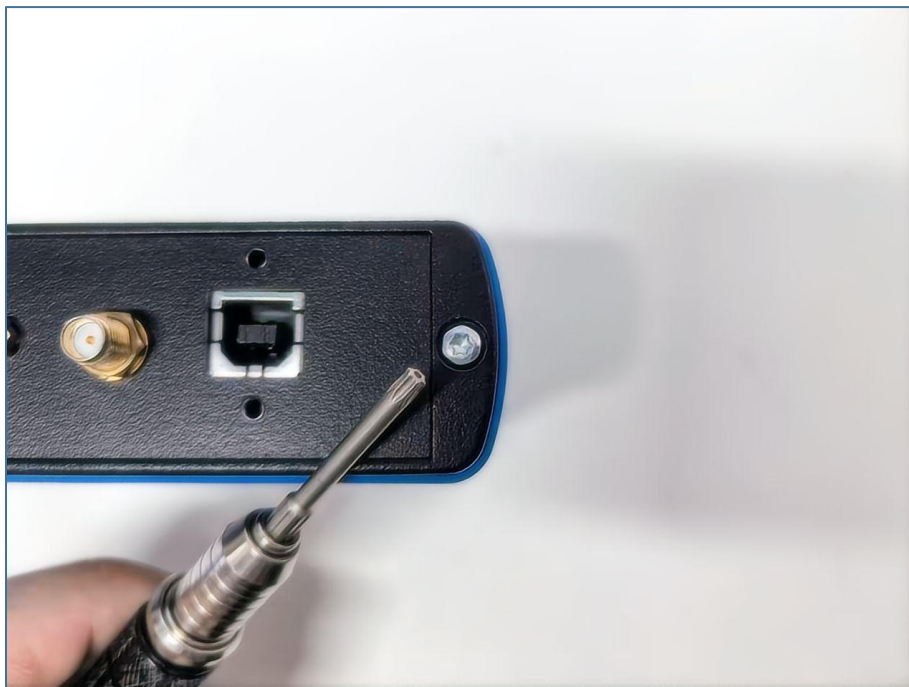

- Remove the end cap, then take the internal circuit board out of the enclosure.



- Using tweezers, gently push the copper retaining clip that secures the button cell outward to release it.

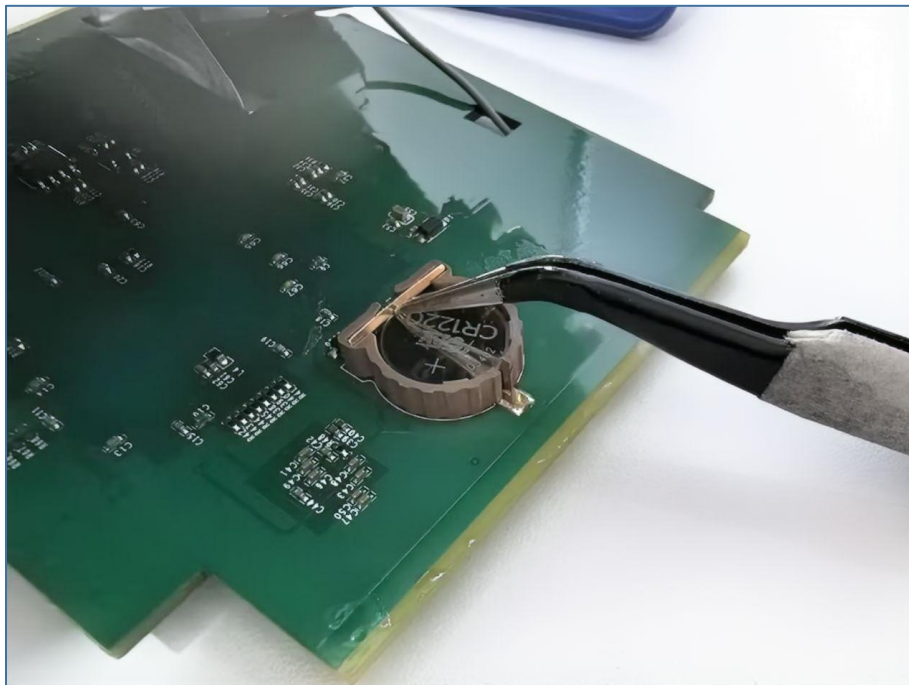

- As shown in the figure, use tweezers to pry up and remove the button cell battery. The battery removal procedure is now complete.

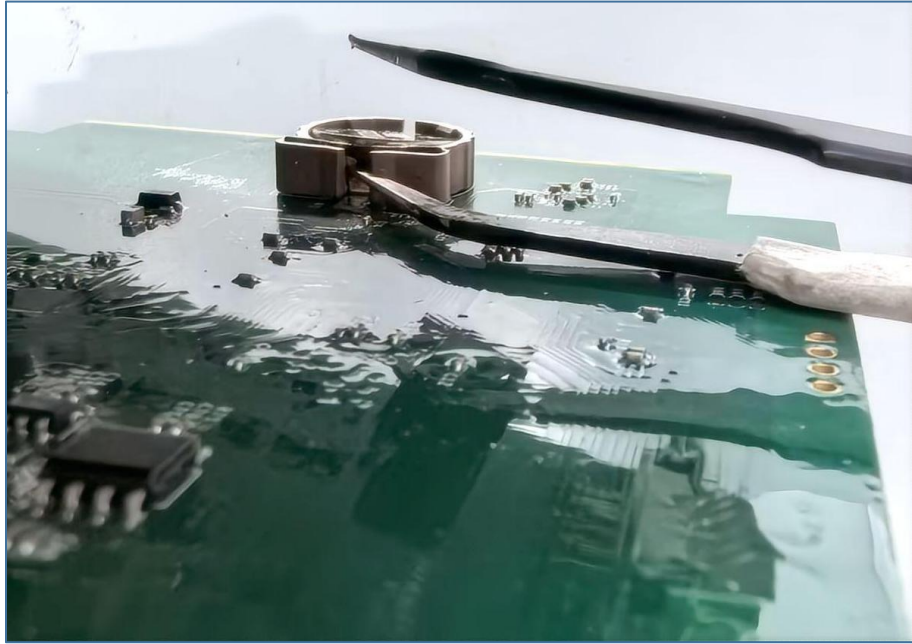

Software

- Support CAN(FD)/LIN/FlexRay/SOME/IP and DoIP
- UDS diagnostics/ECU flashing/CCP/XCP calibration
- Embedded code generation/Application builder
- Encrypted release/Logging and bus replay
- Graphical programming/Residual bus simulation
- C and Python scripting
- Bus monitoring/Transmitting/Automated testing

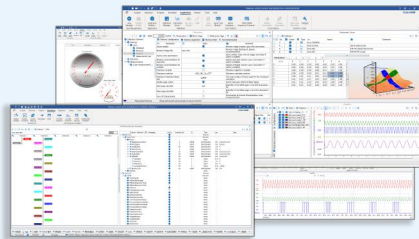

TSMMASTER

Hardware

- 1/2/4/8/12-channel CAN FD/CAN to USB/PCIe device
- 1/2/6-channel LIN to USB/PCIe device
- Multi channel FlexRay/CAN FD to USB/PCIe device
- Multi channel automotive Ethernet/CAN FD to USB/PCIe device
- Automotive Ethernet media conversion device (T1 to Tx)
- Multi-channel CAN FD/Ethernet/LIN datalogger



TTS test systems

- CAN FD/CAN/FlexRay/LIN communication boards
- Relay and fault injection boards
- Resistors for sensor simulation
- Digital I/O, Analog I/O boards available



Solutions

- Bus Conformance
- Network Automation Testing System
- Charging Testing System
- EMB Calibration Testing Equipment
- Information Security Solutions
- Steer-by-Wire Chassis Testing Solutions
- EOL Testing Equipment
- Motor Performance
- Durability Testing Solutions
- FCT



About TOSUN

The core product, TSMaster, is a comprehensive tool for automotive R&D, testing, production, and after-sales. It integrates essential functions with hardware support to streamline processes and ensure precision, making it ideal for automotive professionals.

International Organization



Quality Assurance
ISO9001:2015

CE Certification



Contact Us :

+86 21-5956 0506
sales@tosunai.com

website :

www.tosunai.com

